

Laboratory 7: Series and Parallel Circuits

1 Bulbs in Series and Parallel: Qualitative Observations

The following exercises and demonstrations consider circuits which contain bulbs connected in various arrangements. Your predictions will all be qualitative and rely on the fact that, for identical bulbs the brightness increases when the current through the bulb increases. Assume that all the bulbs involved in the following circuits are identical.

- a) Consider the circuit in Fig. 1.

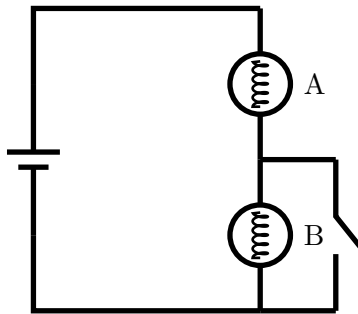

Figure 1: Bulbs in Series

Predict the brightnesses of the bulbs (in comparison to each other) when the switch is closed. Explain how you reached your predictions. This is an example of a *short circuit*.

- b) Predict how the brightness of through bulb A compares to that of bulb B when the switch is open. Justify your prediction.

c) Predict how the brightness of bulb A when the switch is open compares to that of bulb A when the switch is closed. Justify your prediction.

d) Build the circuit and check whether your predictions are correct (for both switch open and closed).

e) Consider the circuit in Fig. 2.

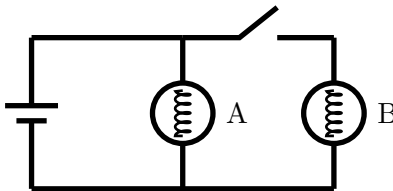

Figure 2: Bulbs in Parallel

Predict the brightnesses of the bulbs (in comparison to each other) when the switch is open.

f) Predict how the brightness of bulb A compares to that of bulb B when the switch

is closed. Justify your prediction.

g) Predict how the brightness of bulb A when the switch is open compares to that of bulb A when the switch is closed. Justify your prediction.

h) Predict how brightness of through bulb A in the series circuit of Fig. 1 (closed switch) compares to that of bulb A in the parallel circuit of Fig. 2 (open switch). Justify your prediction.

i) Build the circuit and check whether your predictions are correct (for both switch open and closed).

2 Resistors in Series and Parallel: Quantitative Observations

Bulbs are typically non-Ohmic devices and resistors are more suitable for a quantitative analysis of circuits. In the following set of experiments you will work with a set of three different resistors connected in various ways.

- a) Select three different resistors and measure their resistance using a multimeter on the “Ohms” setting. **Note:** the multimeter has its own power supply for measuring resistance. Simply connect the terminals to the isolated resistor. Record the resistance of each resistor.
- b) **Series circuit:** Choose two resistors and connect them in a series circuit together with a switch and a battery. Ensure that the switch is open. Draw a circuit diagram that represents this.
- c) **Series circuit:** Predict the currents through and the potential differences across the resistors when the switch is closed. Predict the current through the battery.
- d) **Series circuit:** Close the switch and measure all the currents and potential differences that you predicted above. In each case determine the percentage difference between the theoretical and measured quantities.
- e) **Parallel circuit:** Choose two resistors and connect them in a parallel circuit together with a switch and a battery. Ensure that the switch is open. Draw a circuit diagram that represents this.
- f) **Parallel circuit:** Predict the currents through and the potential differences across the resistors when the switch is closed. Predict the current through the battery.
- g) **Parallel circuit:** Close the switch and measure all the currents and potential differences that you predicted above. In each case determine the percentage difference between the theoretical and measured quantities.
- h) **Series/parallel combination:** Choose three resistors and connect two in a parallel circuit and a third in series with this and a switch and a battery. Ensure that the switch is open. Draw a circuit diagram that represents this.
- i) **Series/parallel combination:** Predict the currents through and the potential differences across the resistors when the switch is closed. Predict the current through the battery.
- j) **Series/parallel combination:** Close the switch and measure all the currents and potential differences that you predicted above. In each case determine the percentage difference between the theoretical and measured quantities.

3 Exercises

- a) Consider your series circuit. Determine the total charge that flows through each resistor in 20 s. Determine the amount of energy required to push this charge through each of the resistors.
- b) In the circuit below predict the current through and voltage across each resistor if the potential difference across the battery is 1.5 V. Determine the power dissipated by each resistor.

